

Receiver Specification

Our Part No		13M06H-15WF8-5A22	
Size	Diameter 13mm	Total Height	5.5 mm
No.	Item	Specification	Testing Condition
1.	Rated Imp	8ohm \pm 15%	At 1 kHz 1.0V
2.	D.C Impedance	7.4ohm \pm 10%	At 20°C
3.	Output S.P.L.	114 \pm 3dB	At 1mW IEC318 1KHz
4.	Input Power	Rated Power: 30mW	Max Power: 50mW
5.	Frequency Range	300---4000Hz	Output S.P.L. -10dB
6.	Operation	Must Be Normal	Program Source 30mW
7.	Buzzes & Rattles	Must Be Normal	Sin Wave 0.49V
8.	Load Testing	After Test Meet 2&7	30mW 96hours White Noise
9.	Distortion	5% Max	Input Rated Power at 1000Hz
10.	Heat Testing	After Test 7&8&9	55°C \pm 2°C 16hours
11.	Cold Testing	After Test 7&8&9	-20°C \pm 3°C 16hours
12.	Humidity Testing	After Test 7&8&9	40°C \pm 2°C 90~95% R.H. 48hours
13.	Insulation Resistance	1M Ω	Dc100v FRA. And TER.
14.	Magnet Size	\varnothing 5.4 \times 0.9	N42
15.	Net Weight	1.4 g/PC	
16.	Polarity	When a positive D.C voltage is applied to the terminal marked red or +, the diaphragm should move to the front.	

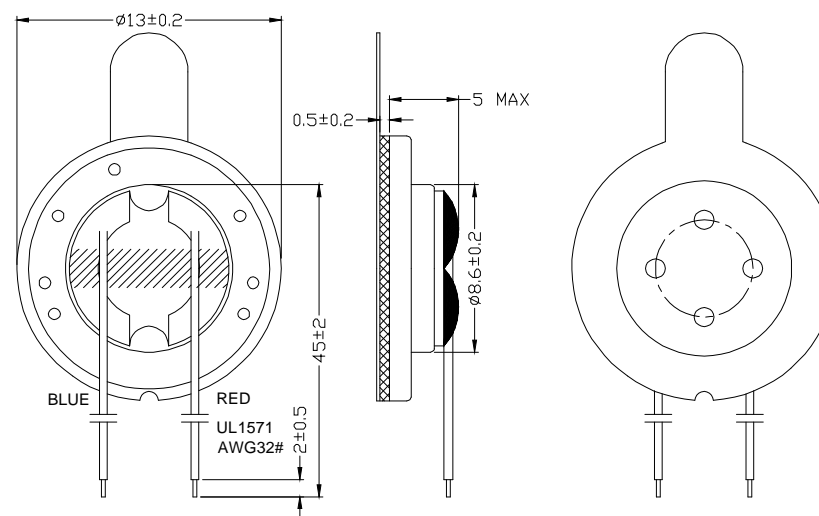
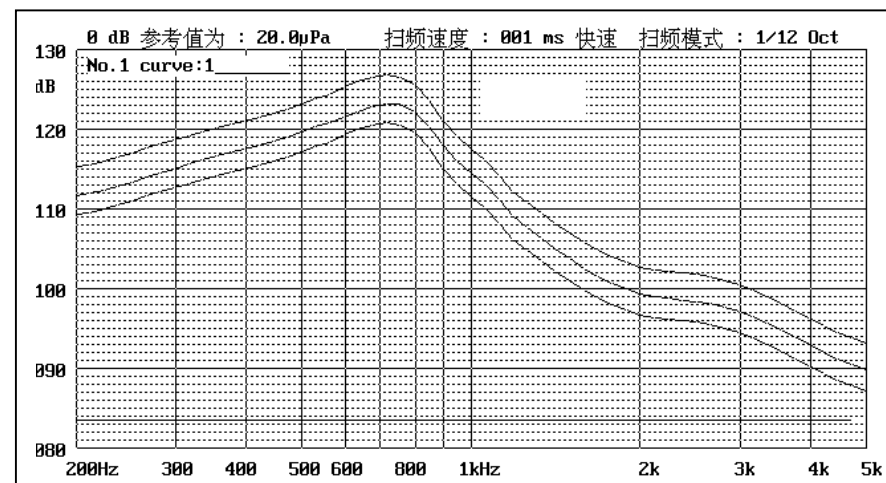

POWER SOUND ELECTRONICS LTD. - Acoustic Components Manufacturer

Tel: +86-755-8423 5076,8423 5093,8423 5316 Fax: +86-755-8423 5085 E-mail: psound@szonline.net

<http://www.chnpowersound.com>