

Mylar Speaker Specification

Our Part No		17M02CH-38YF8-6J28	
Size	Diameter 17mm	Total Height	3.9 mm
No.	Item	Specification	Testing Condition
1.	Rated Imp	8ohm \pm 15%	At 1 kHz 1.0V
2.	Resonance Freq	850Hz \pm 20%	Without Baffle
3.	Output S.P.L.	87 \pm 3dB	At 0.1m 0.1W 1K, 1.2K, 1.5K, 2KHz Average
4.	Input Power	Rated Power: 0.5W	Max Power: 1.0W
5.	Frequency Range	F0----20KHz	Output S.P.L. -10dB
6.	Operation	Must Be Normal	Program Source 0.5W
7.	Buzzes & Rattles	Must Be Normal	Sin Wave 2.0V
8.	Load Testing	After Test Meet 2&7	0.5W 48hours White Noise
9.	Distortion	5% Max	Input Rated Power at 1000Hz
10.	Heat Testing	After Test 7&8&9	+60°C \pm 3°C 48hours
11.	Cold Testing	After Test 7&8&9	-25°C \pm 3°C 48hours
12.	Humidity Testing	After Test 7&8&9	40°C \pm 2°C 90~95% R.H. 24hours
13.	Insulation Resistance	1M Ω	Dc100v FRA. And TER.
14.	Magnet Size	\varnothing 6.5 \times 1.0	N42
15.	Net Weight	1.75 g/PC	
16.	Polarity	When a positive D.C voltage is applied to the terminal marked (+) or red, the diaphragm should move to the front.	

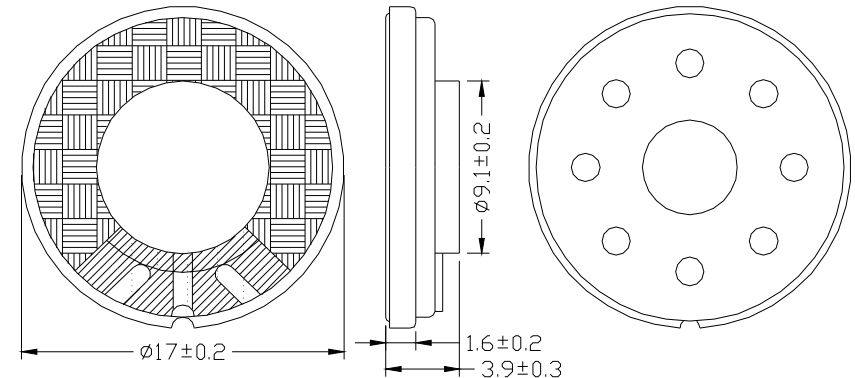
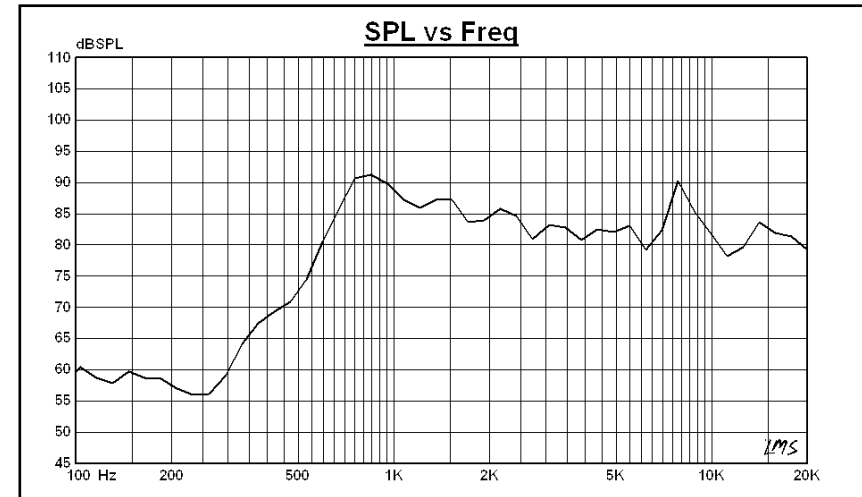

POWER SOUND ELECTRONICS LTD. - Acoustic Components Manufacturer

Tel: +86-755-8423 5076,8423 5093,8423 5316 Fax: +86-755-8423 5085 E-mail: psound@szonline.net

<http://www.chnpowersound.com>